

Pentaflake, in Google SketchUp

I love fractals, and recently ran across this one. Here's the definition of a pentaflake from Wolfram Mathworld (<http://mathworld.wolfram.com/Pentaflake.html>):

Pentaflake: a fractal with 5-fold symmetry. Five pentagons can be arranged around an identical pentagon to form the first iteration of the pentaflake. This cluster of six pentagons has the shape of a pentagon with five triangular wedges removed.

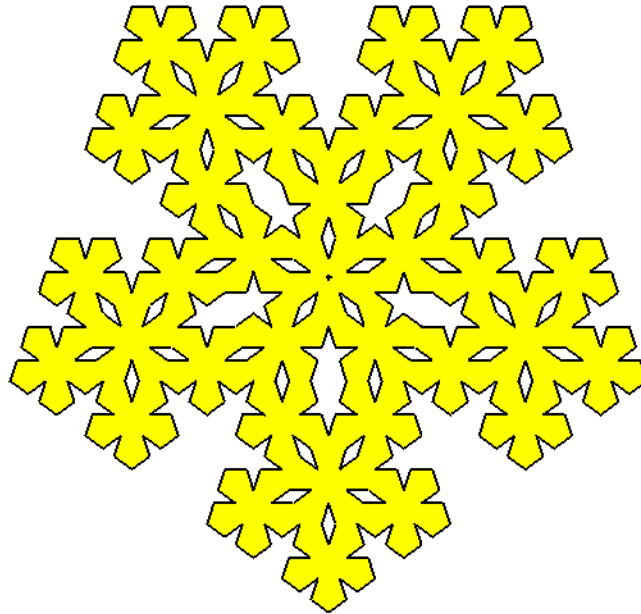

All you need to create this is a few SketchUp tools - it's easier than it looks!

This project will work in any version of SketchUp, including the recently-released Version 8.

First Iteration

1. Open Google SketchUp. If your file contains a person standing on the ground near the origin, click the **Eraser** tool and erase him or her.

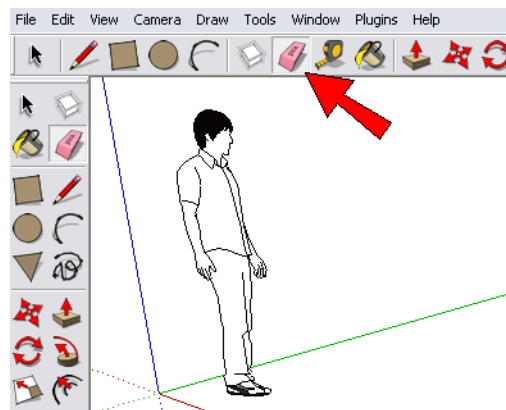

2. From the main menu, choose **Camera / Standard Views / Top**. Now you're looking down on the "ground," and the word **Top** appears in the top left corner of the SketchUp window.

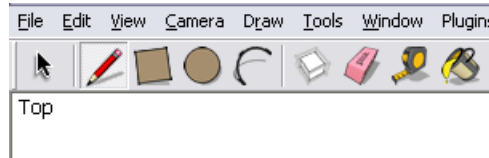

3. To create the first pentagon, go to the main menu and choose **Draw / Polygon**. Before clicking anywhere, look at the **Sides** field, located in the lower right corner of the SketchUp window. By default, the **Polygon** tool creates hexagons, so you should see 6 in this field. To change it to make a pentagon, just type 5 (don't click in the **Sides** field, just type 5 and the number will appear). Then press Enter.



4. Now click twice to create the pentagon: first click to place the center, then move your mouse and click again to complete the pentagon. If you don't like the pentagon's default color, you can use the **Paint Bucket** tool to find a different color or material.

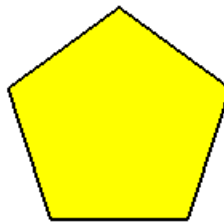

5. We need to identify the center point of this pentagon. So right-click on any *edge* (be sure not to click on the face) and choose **Point at Center**.

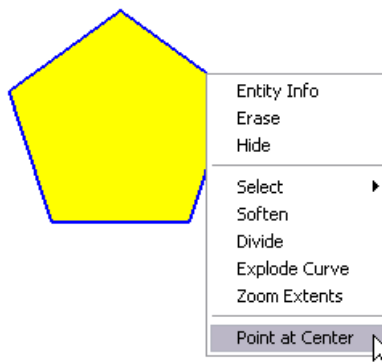

If you don't see the **Point at Center** option, choose **Window / Preferences (PC)** or **SketchUp / Preferences (Mac)**. Open the **Extensions** page and check **Ruby Script Examples**.

This places a small dot at the pentagon's center.

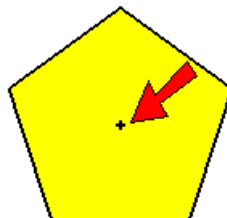

6. Now we're going to create the first copy of the pentagon, which will actually be a mirrored copy. The first step is to select what's going to be copied, so click the **Select** tool (click the icon shown below or press the Spacebar), and click the pentagon face to select it.

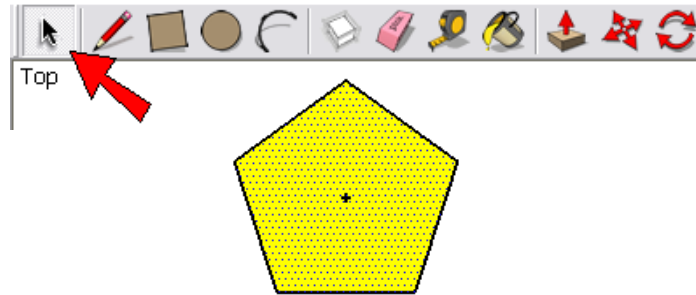

7. With the pentagon selected, click the **Rotate** tool (click the icon shown below or press the Q key).



8. Usually when using **Rotate**, the first click defines the center of rotation, but we're going to use **Rotate** a different way: to define a specific *axis of rotation*. So move your cursor to any corner of the pentagon, but don't click yet.

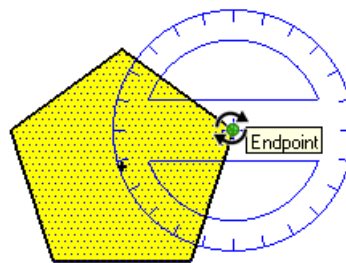

9. Click on this corner, keeping your mouse button pressed. Then drag the cursor to any adjacent corner, and release the mouse button. This makes the protractor vertical (perpendicular to the screen), and the rotation axis is exactly along a pentagon edge.

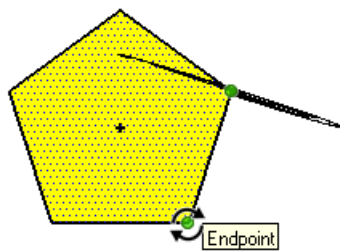

10. To make a copy, press the Ctrl key (PC) or Option key (Mac). You don't have to keep this key pressed; just tap it once. This adds a "plus" sign to your cursor.

11. The next two clicks define the rotational angle, which for a mirrored copy should be 180 degrees. For the first click, move your cursor to some blank space anywhere on the other side of the pentagon from the edge you're using as the rotation axis. Then click.

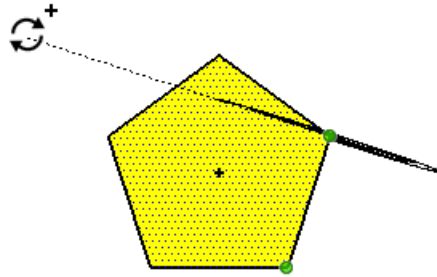

12. For the second click, move your cursor to the other side of the rotation axis. Click when you see the mirrored copy appear, as well as the number 180 in the **Angle** field. (If you can't get 180 to appear, just type 180 and press Enter.)

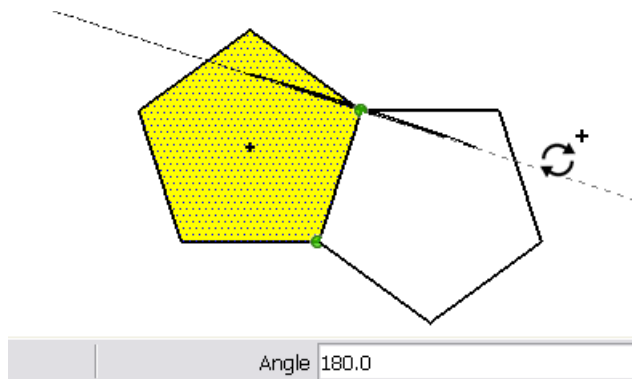

13. This mirrored pentagon has a different color than the original one; you're looking at the default "back face" color because this pentagon is flipped over. To match the two pentagon colors, right-click on the mirrored copy and choose **Reverse Faces**.

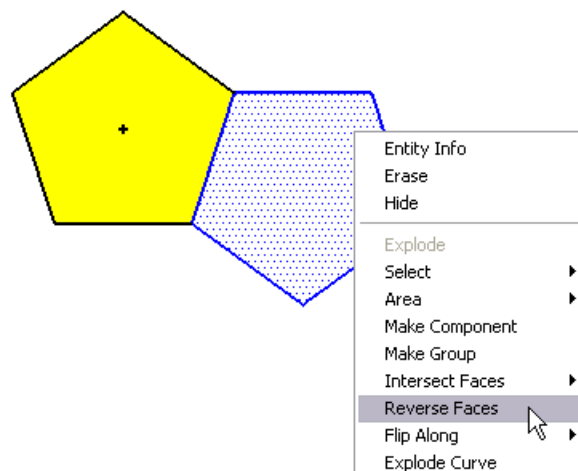

14. The copied pentagon now has the correct color. It should still be selected; leave it selected.

15. With the copied pentagon still selected, and the **Rotate** tool still active, we can now make four more rotated copies. The first click sets the center of rotation, so click the marked center point of the original pentagon.

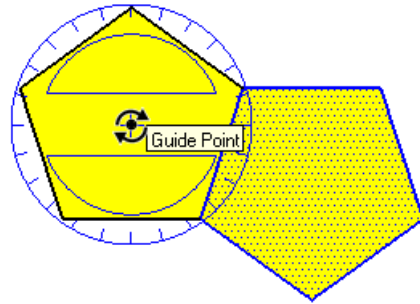

16. Press Ctrl or Option again, and for the rotation angle, click any two adjacent corners of the original pentagon. The rotation angle should be 72 degrees - why?

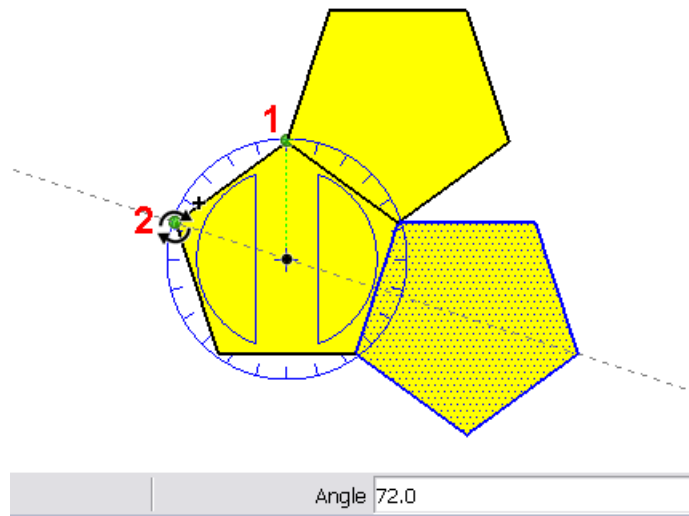

17. Immediately after placing the copy, type 4x, which appears in the **Angle** field, and press Enter. This creates four copies of the pentagon, resulting in five total pentagons surrounding the original.

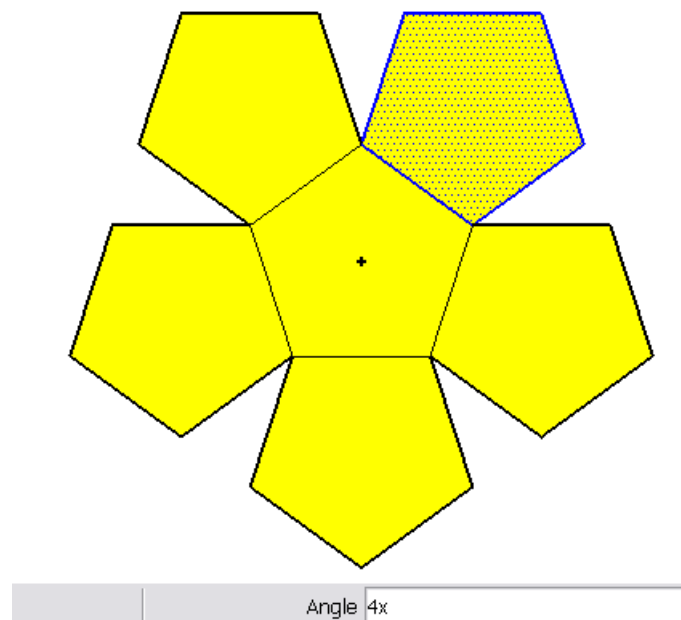

18. The last step to complete the first pentaflake iteration is to remove all of the interior edges, such as the ones shown below. Click the **Eraser** tool (or press the E key), and click the five edges of the original pentagon. Don't erase the center point - we'll still need to use that.

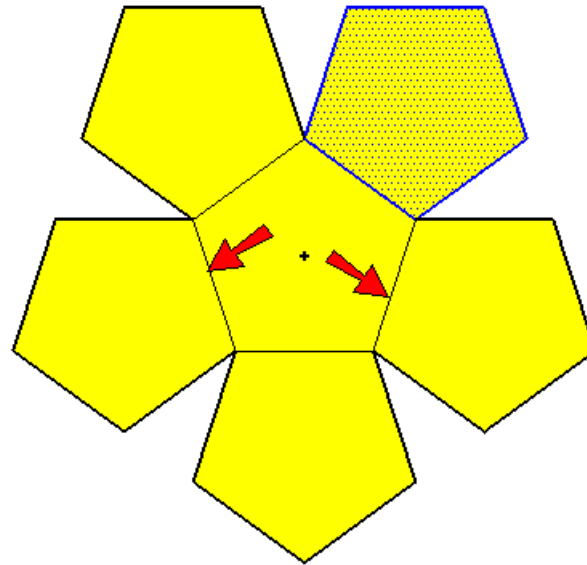

Here is the first iteration: one single face. (If you were to connect the five outer corners, you would get another perfect pentagon.)

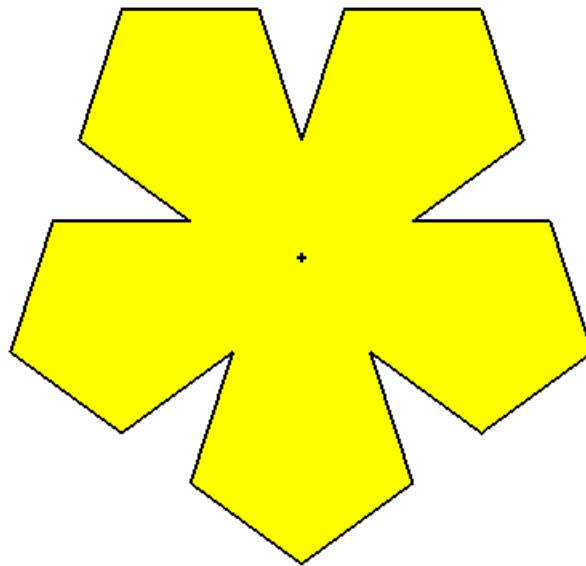

More Iterations

1. For the second iteration, we'll follow the same steps we used for the first iteration. First, use the **Rotate** tool to make a mirrored copy of the pentaflake.

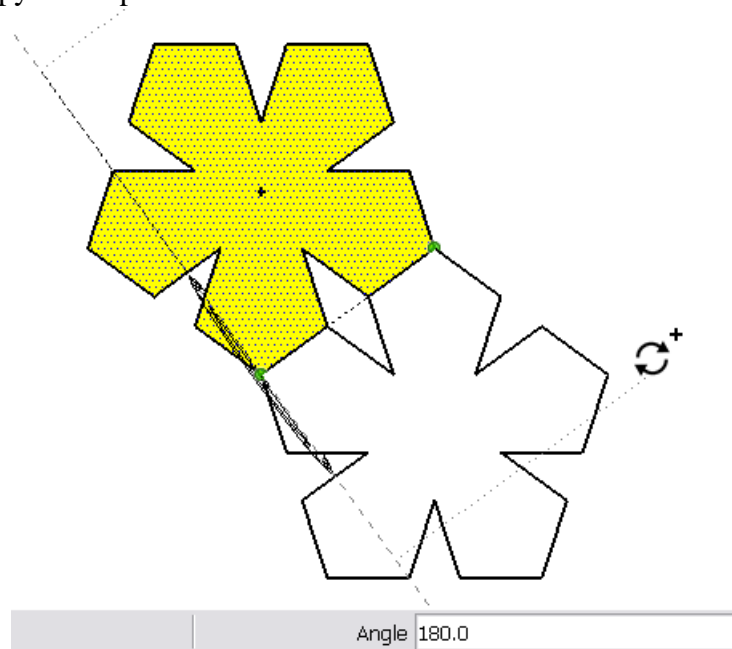

2. Reverse the face, then make four rotated copies around the center point.

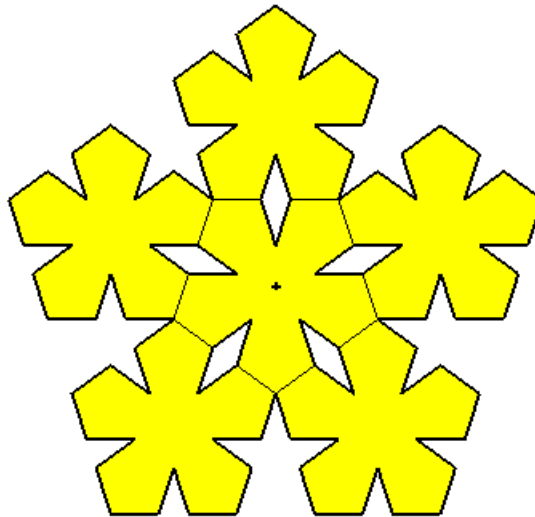

3. Erase all of the interior edges (there will be 10 this time), and here's the second pentaflake iteration:

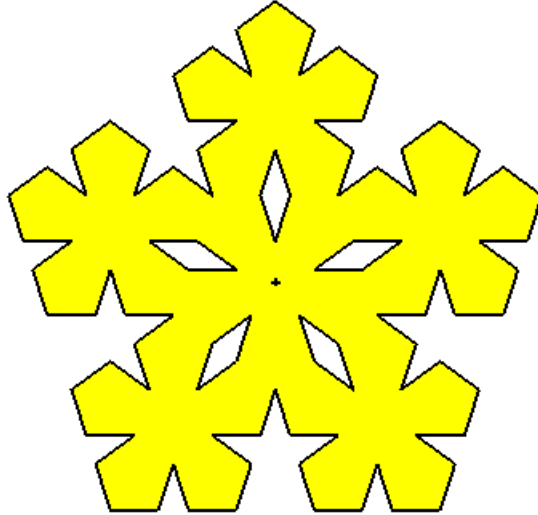

4. Following the steps again, get the third iteration:

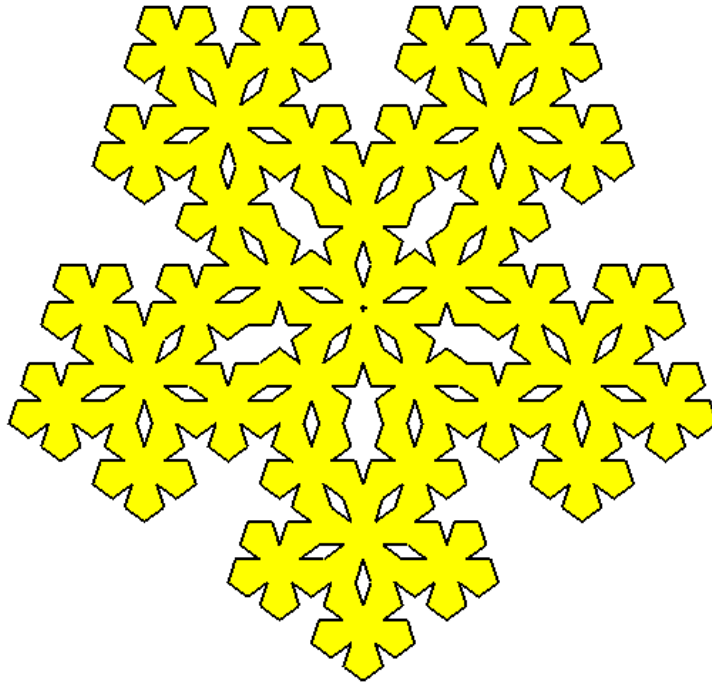

5. If you don't mind working with many very small edges, continue to the fourth iteration. How many edges will you have to erase with this one?

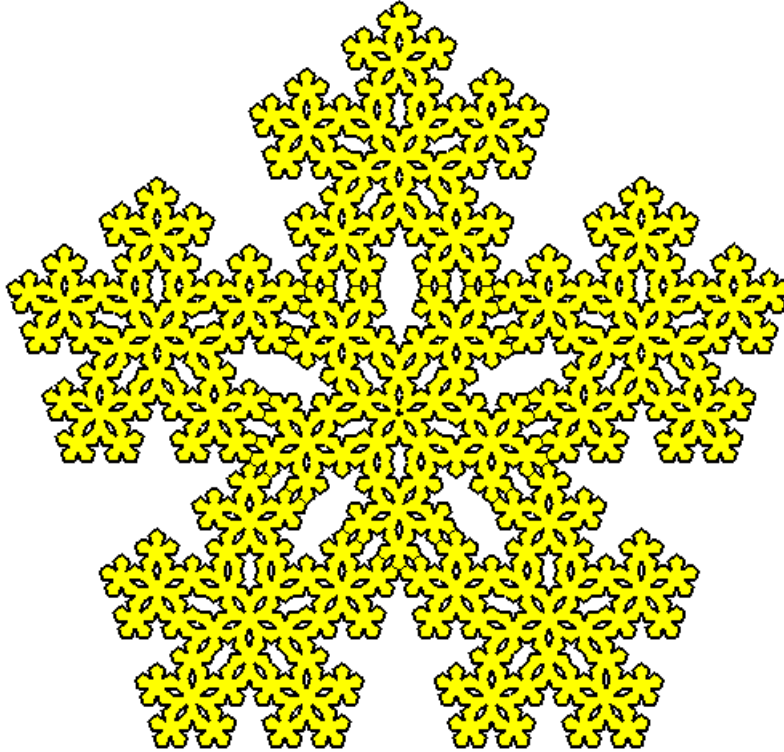

6. I continued to iteration #5, which took SketchUp a bit of time to complete, and had way too many edges to erase! But it looks very cool with the edges hidden, which you can do in the **Styles** window.

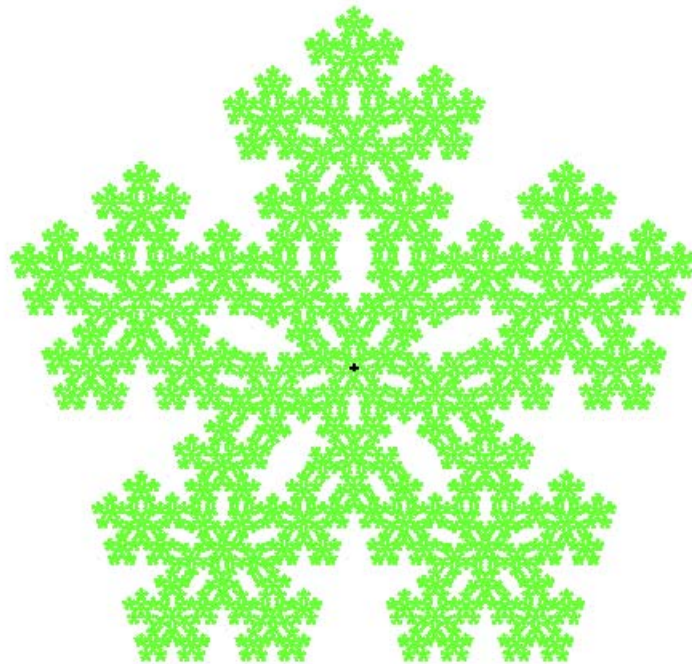
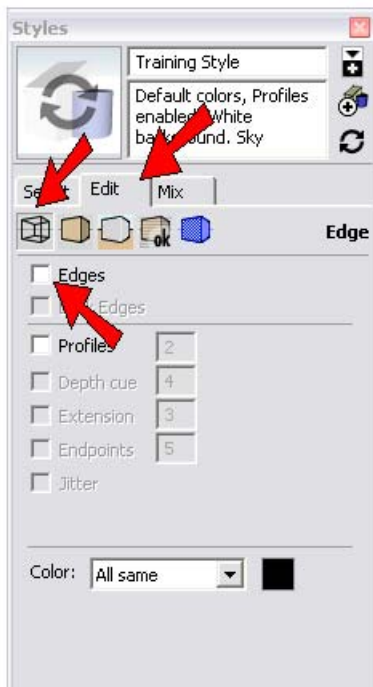

Try This

Use the **Line** tool to trace a pentagon around the corners of the pentaflake. This creates some new faces inside the pentaflake. For faces that were not completed, use the **Line** tool to trace around their edges to fill them in. (Remember, you don't have to fill in each and every face - you can fill in one-fifth of them, and rotate-copy them around the center!) Then you can paint your pentaflake in some interesting patterns.

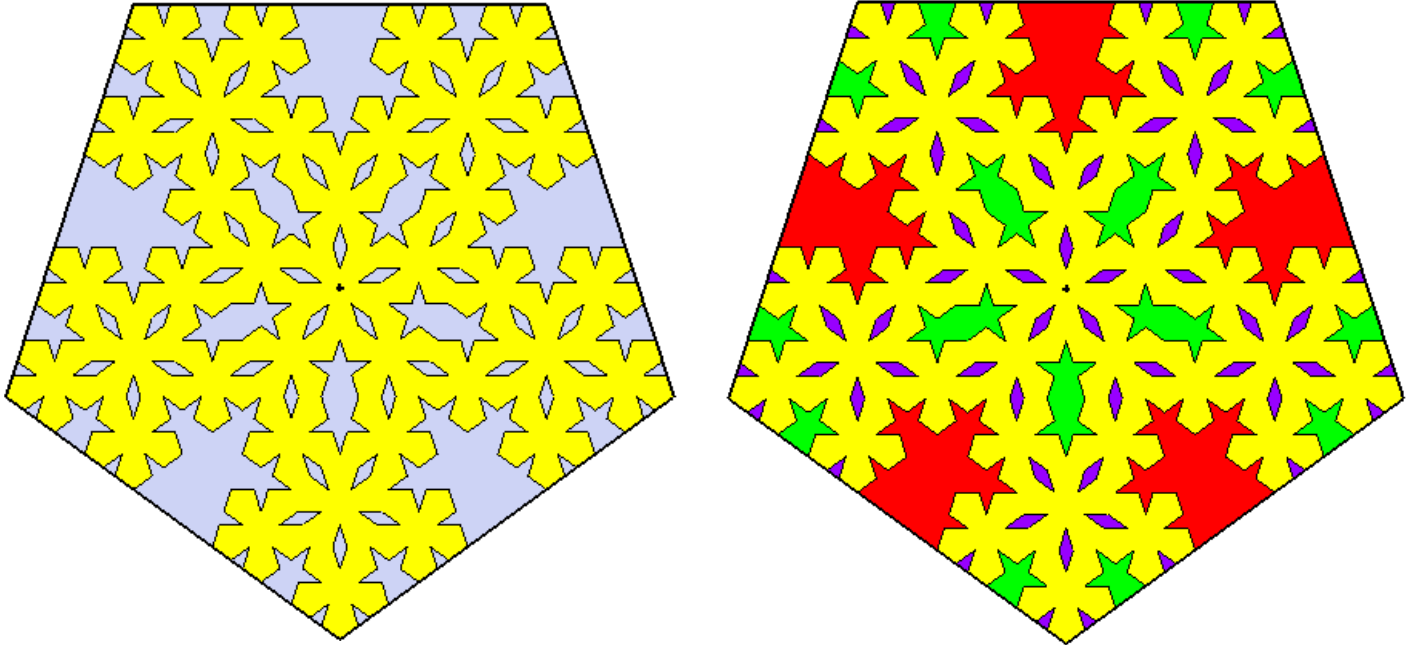

Here's my painted fourth iteration, with edges hidden:

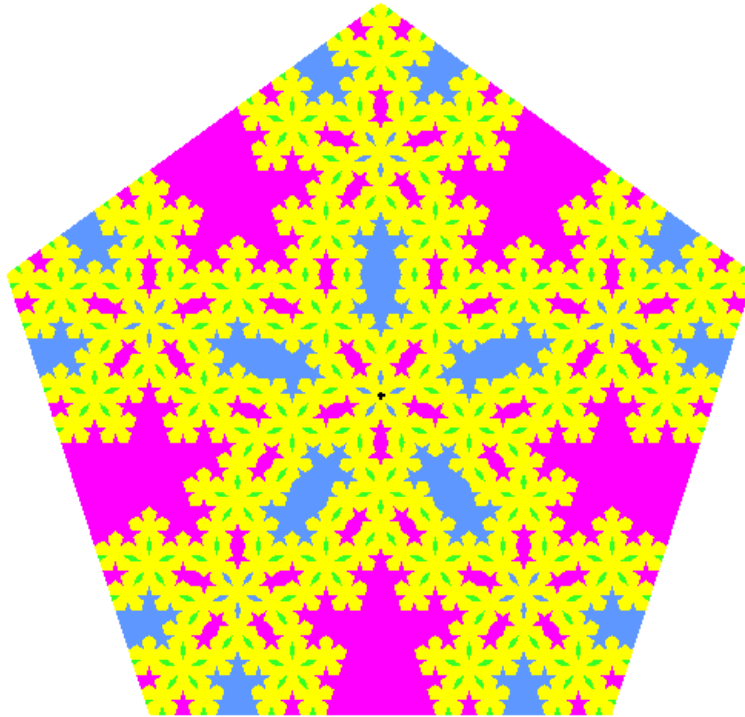

And here's my painted fourth iteration, copied around itself:

