

Hexagonal Pyramid in Google SketchUp

This project seems simple (and it is) but it shows that there is often more than one way to create something in SketchUp. The object in this case is a hexagonal pyramid, but you can use this project on any type of pyramid.

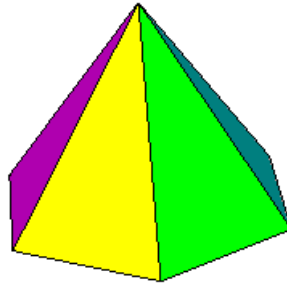

This project will demonstrate two ways to create this object, but you may be able to come up with other methods.

This project will work in any version of SketchUp, including the recently-released Version 8.

Teacher Note: All text that appears in **red** is for the teacher version only, and does not appear in the student version.

For this project, it helps to have some basic knowledge of Google SketchUp (though detailed instructions are provided). In particular, it's important to know how to zoom, orbit, and pan the view. If you need more information on how to get started, and a description of some basic tools, please read 3DVinci's Getting Started Guide (PDF).

PC users: go to http://www.3dvinci.net/SketchUp_Intro_PC.pdf.

Mac users: go to http://www.3dvinci.net/SketchUp_Intro_MAC.pdf.

Method 1: Scale the Top

In this method, you'll start with a hexagon, make it into a prism, and shrink the top to create the pyramid.

1. Open Google SketchUp. If your file contains a person standing on the ground near the origin, click the **Eraser** tool and erase him or her.

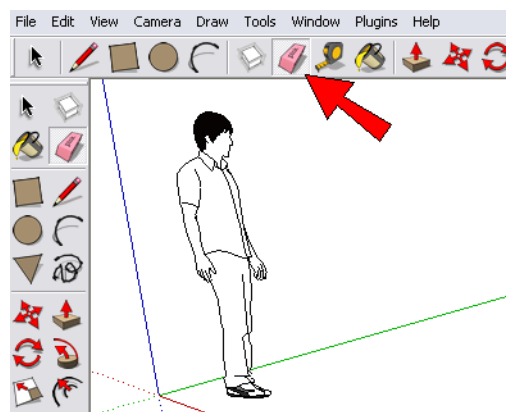

2. From the main menu, choose **Camera / Standard Views / Top**. Now you're looking down on the "ground," and the word **Top** appears in the top left corner of the SketchUp window.

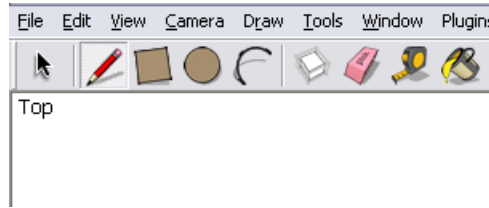

3. To create the hexagon for the base, go to the main menu and choose **Draw / Polygon**. Before clicking anywhere, look at the **Sides** field, located in the lower right corner of the SketchUp window. By default, the **Polygon** tool creates hexagons, so you should see 6 in this field. If you see a different number, type 6 and press Enter. (Don't click inside this field; just type and the number will appear.)



4. Now create the hexagon with two clicks: the first click places the center, then move your mouse and click again to complete the hexagon.

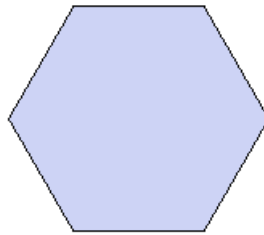

5. To make the hexagonal prism, activate the **Push/Pull** tool, click the hexagon, and pull it up.

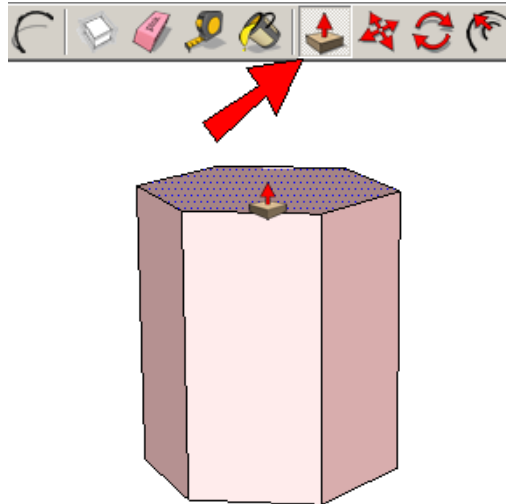

6. Activate the **Select** tool and select the top face of the prism.

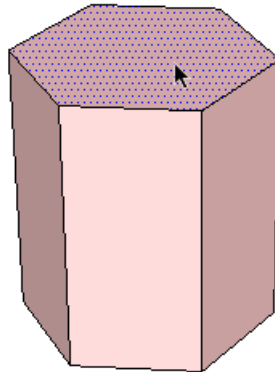

7. With the top face selected, activate the **Scale** tool (menu: **Tools / Scale**). A set of eight green boxes appears - these are drag handles you can use to resize the selected object(s). Hover over one of the corner handles, and the popup tells you that the scale will be relative to the opposite point.

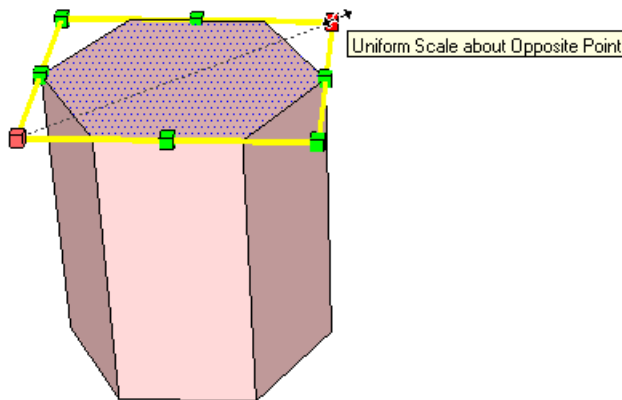

8. But we want the scale to be about the *center* of the hexagon face. So press and hold the Ctrl key (PC) or Option key (Mac), and the popup changes.

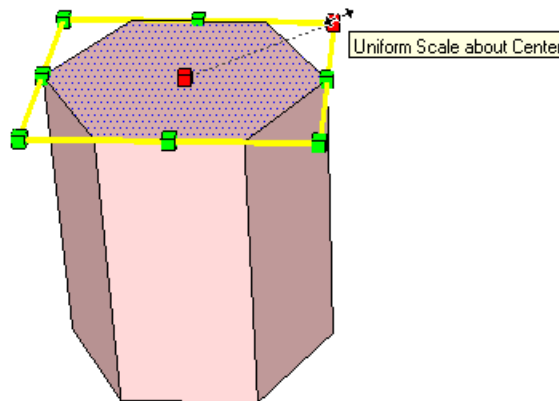

9. Keep Ctrl or Option pressed, and drag the corner inward. The 3D shape you get is a truncated hexagonal prism - the top is smaller but still flat.

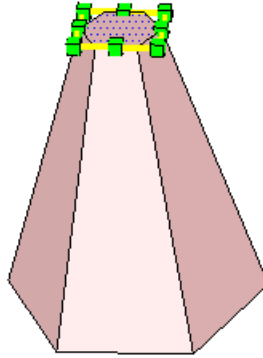

10. To make an actual pyramid, ending at the top at a single point, keep scaling inward until the top face flips inside-out.

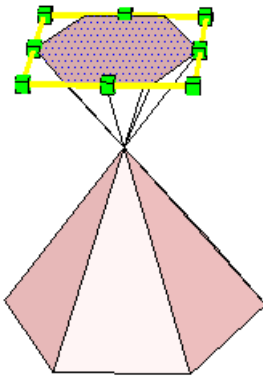

11. To remove the top part, activate the **Eraser** and click each edge you want to remove. This will also remove some of the pyramid faces, but we'll replace them in the next step.

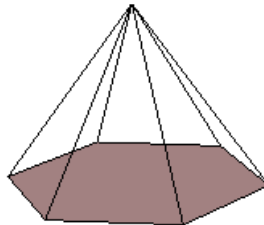

12. To replace the faces, activate the **Line** tool and trace over edges until the faces return. (If you want to give your pyramid some color, click the **Paint Bucket** tool and find some materials or colors you like.)

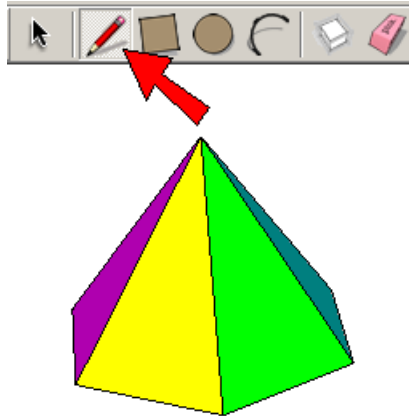

Method 2: Fix the Top Point

This method gets you the same pyramid, but all of the faces are drawn from a point that defines the tip of the pyramid.

1. Start again with a hexagon on the “ground.”

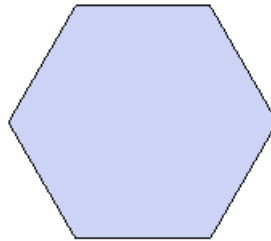

2. Orbit so the hexagon appears almost flat, and activate the **Line** tool. Before clicking anywhere, hover your cursor over one of the hexagon corner points. (This “reminds” SketchUp of the hexagon’s geometry, so that other points will be easy to find later.)

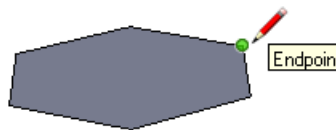

3. Then move your cursor to the center of the hexagon and click when the center point highlights.

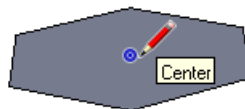

4. For the second point, move your cursor straight up (blue direction). If you want, you can press the up or down arrow to “lock” this direction. Click anywhere above the hexagon - this will be the tip of the pyramid.

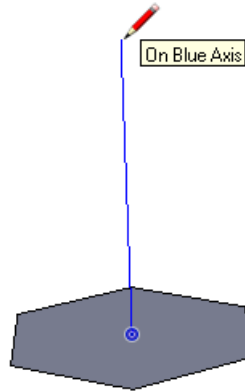

5. Now use the **Line** tool to connect the tip to each corner of the hexagon.

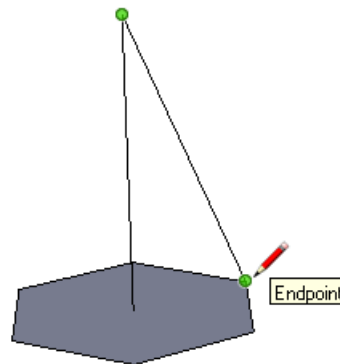

6. When all faces are complete, you get the same pyramid as before (though maybe a different size).

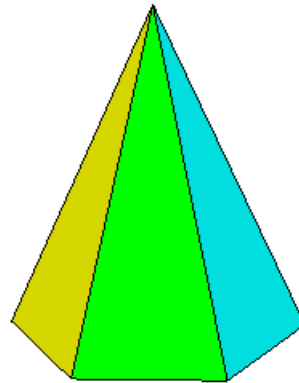

7. However you make your pyramid, you can make it taller or shorter. Just activate the **Move** tool, click the tip point, and move the point up or down.

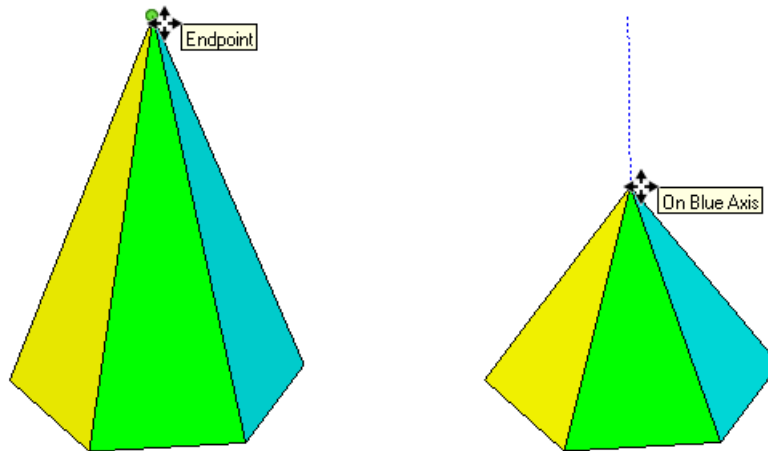

Can You Do This?

You can also make a pyramid by starting with its net - all seven faces lying flat. To make the faces shown below, you would first create the hexagon, then create one triangle (using the hexagon edge's midpoint as a guide), and finally rotate-copy the triangle around the hexagon center.

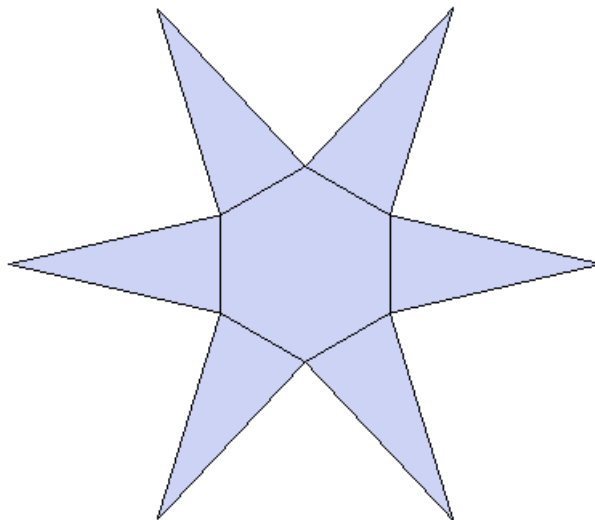

But how do you know how far to fold up each triangle? You probably know you need to make a vertical line from the hexagon center. But how do you get the triangle tip to meet this line?

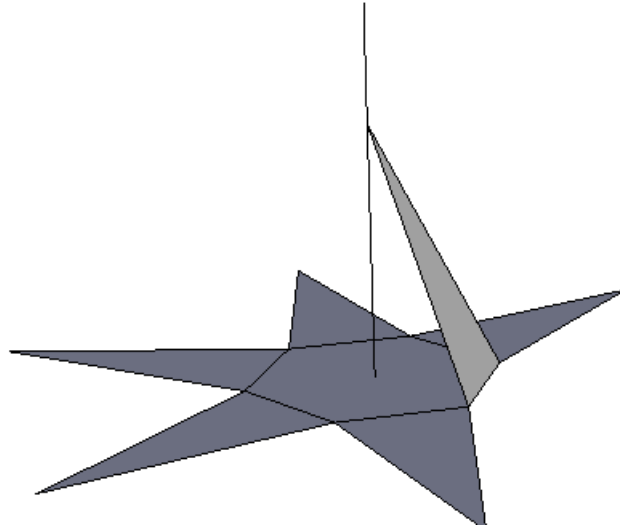

Teacher Note: To solve this, you need to make a vertical circle whose center is the midpoint of a hexagon edge, and whose circumference lies on the tip of a triangle. Where this circle meets the vertical edge defines how far you fold the triangle.

This construction will be shown in illustrated detail in one of our December 2010 Projects of the Month. To subscribe, to go [SketchUp Project of the Month](#).

Teachers, Want More?

For more projects with 3D geometry, you'll love 3DVinci's GeomeTricks books on Platonic, Archimedean, and related solids:



All books are available in print and as printable PDF. For details on GeomeTricks, go to <http://www.3dvinci.net/ccp0-catshow/GM.html>.

If you sign up for our [SketchUp Project of the Month](http://www.3dvinci.net/ccp0-prodshow/POM.html) subscription, each month you will receive **THREE FUN PROJECTS** (one in math, two in 3D design) that can be used in K-12 classes. Details at <http://www.3dvinci.net/ccp0-prodshow/POM.html>. November's project shows how to animate the iterative progression of a hexaflake:

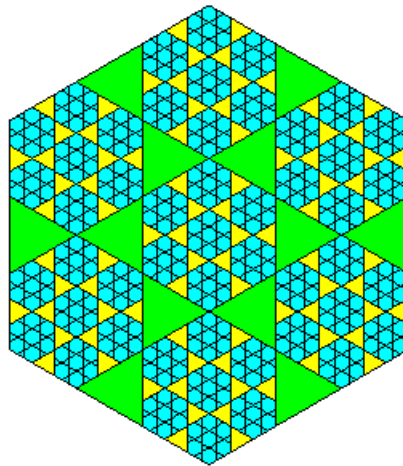

To view this animation, see our blog post: <http://3dvinci.blogspot.com/2010/11/our-november-projects.html>.